

2020 Water Wave Wall Washer Light

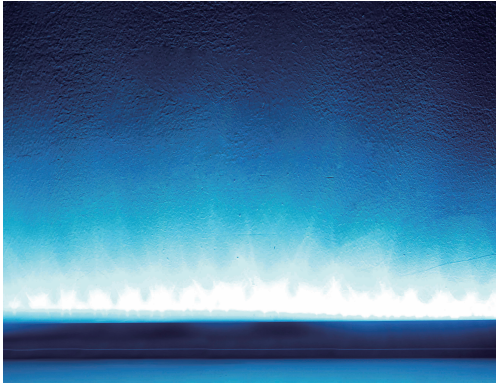

- Made of high-toughness flexible silicone material, allowing for arbitrary bending.
- Supports both SPI and DMX control protocols, adaptable to different application scenarios.
- The water ripple projection is clear, natural, vivid and smooth, casting dynamic water patterns onto walls to create a natural ambiance.
- The water ripple effect produces a mild hypnotic effect, suitable for comfort-focused spaces such as bedrooms and therapy rooms.
- It can operate stably for a long time in complex environments with high humidity, dust, etc., suitable for a wide range of indoor and outdoor scenarios.
- Protection rating reaches IP65.

Technologies

- SPI, DMX

Application

- Application: Home Decoration, Including Construction Projects, Buildings, Hotels, Malls, Indirect Lighting, Cove Lighting, Accent Lighting

Color Options



Dimensions

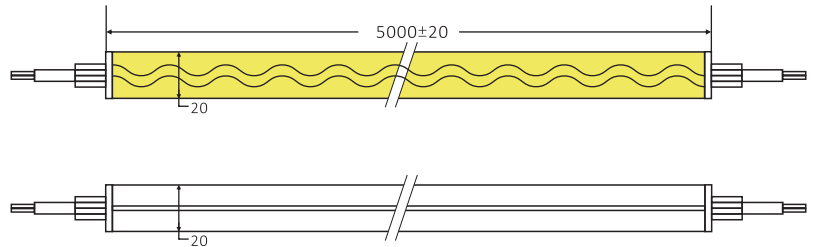

Beam Angle

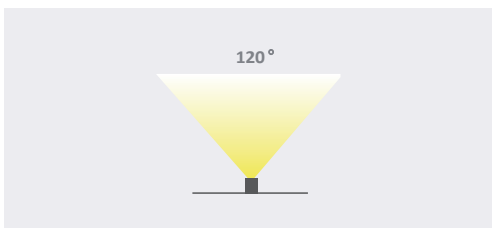

Sectional Drawing

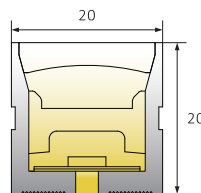

Product Specifications

P/N	LED	CCT k	CRI	LEDs/M	LUMENS (lm/m)	Voltage (v)	Current (mA/M)	Power (W/M)	Cut Length (MM)	Max Run (M)
RL-FV2414070505014-865-DMX-FWD2020	5050	R;620-625nm	W:80	70	36	24	0.217	5.20	100	5
		G;525-530nm			88		0.217	5.20		
		B;467.5-472.5nm			21		0.217	5.20		
		W:6500K			112		0.217	5.20		
		RGBW			253		0.600	14.40		
RL-FV2414070505014-865-SPI-FWD2020-10PIXEL	5050	R;620-625nm	W:80	60	30	24	0.217	5.20	100	5
		G;525-530nm			80		0.217	5.20		
		B;467.5-472.5nm			18		0.217	5.20		
		W:6500K			100		0.217	5.20		
		RGBW			220		0.600	14.40		

Other Specifications

Protection grade	IP65
Working temperature(°c)	-25~+40
Storage environment temperature (°c)	-25~+70
Standard length	5
Maximum cascade length(m)	5
weight	/

Remark

- The test environment temperature is 25±2°C;
- The above data are typical values, the actual parameters of the product may be different from the typical data; the data is subject to change without notice;
- The above "/" means that this parameter is not required for the time being.

Applied Standards



Installation

Note :Due to the different types and attributes of neon lights, please refer to the, line marks forthe bending radius

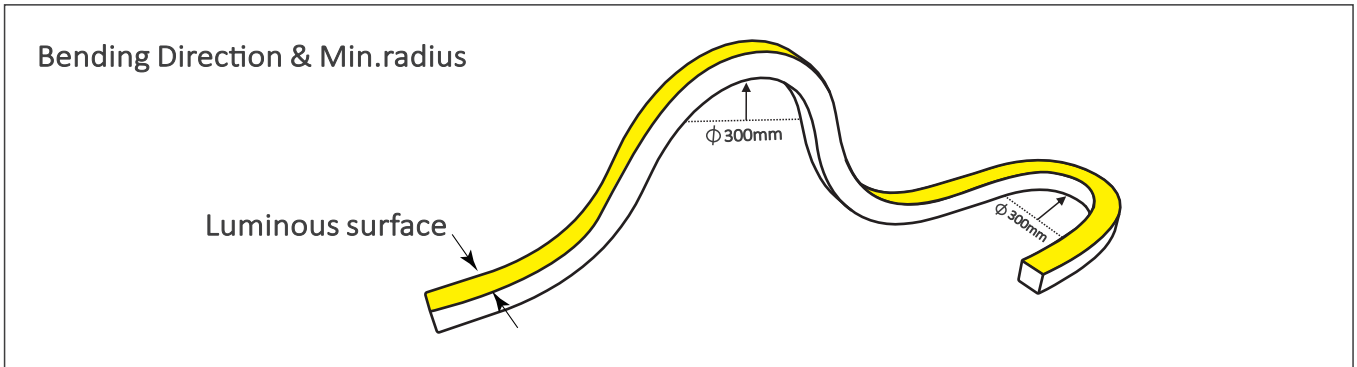

Mounting with aluminium profiles

Install with the screws provided. Do not use screws of othertypes or sizes that do not meet requirements.

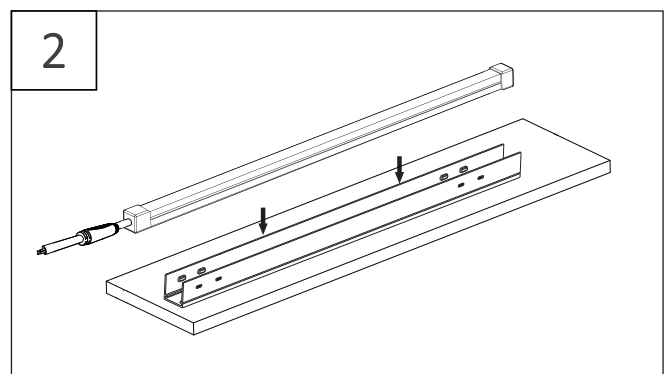
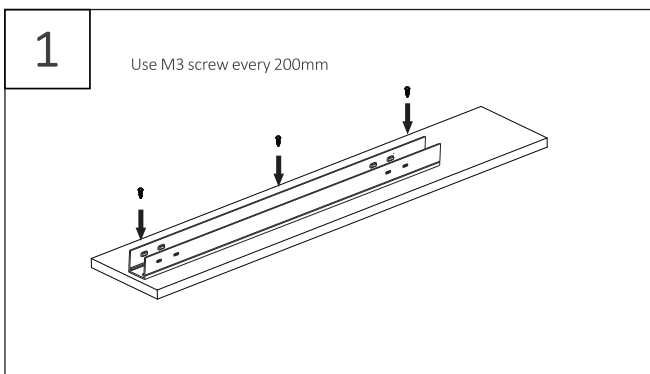
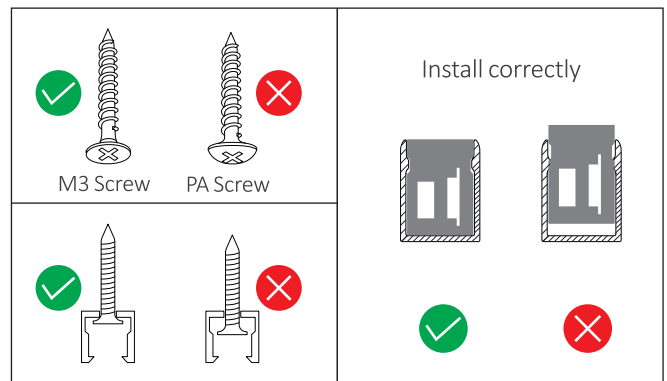
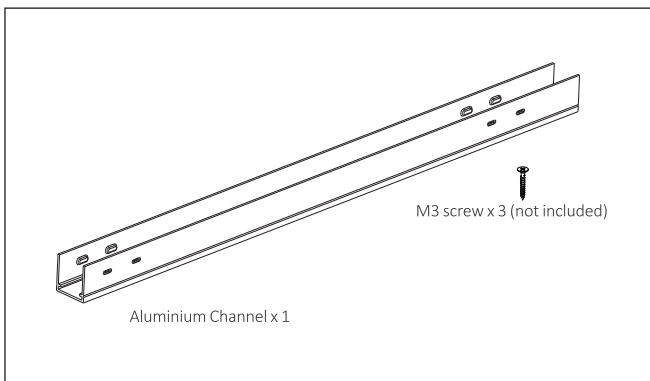

Schematic diagram of electrical connection

1. SPI wiring diagram: Power + controller + light belt connection mode

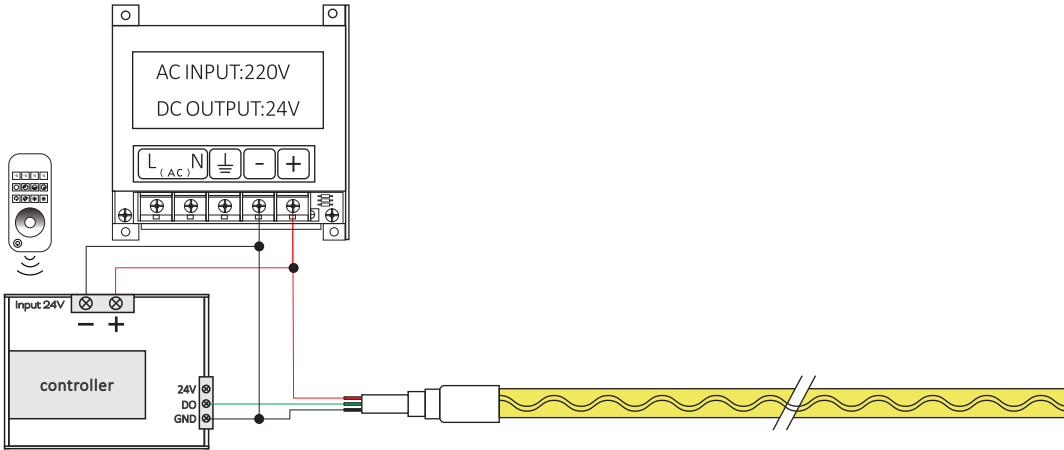

2. DMX512 wiring diagram: Power + controller + light belt connection

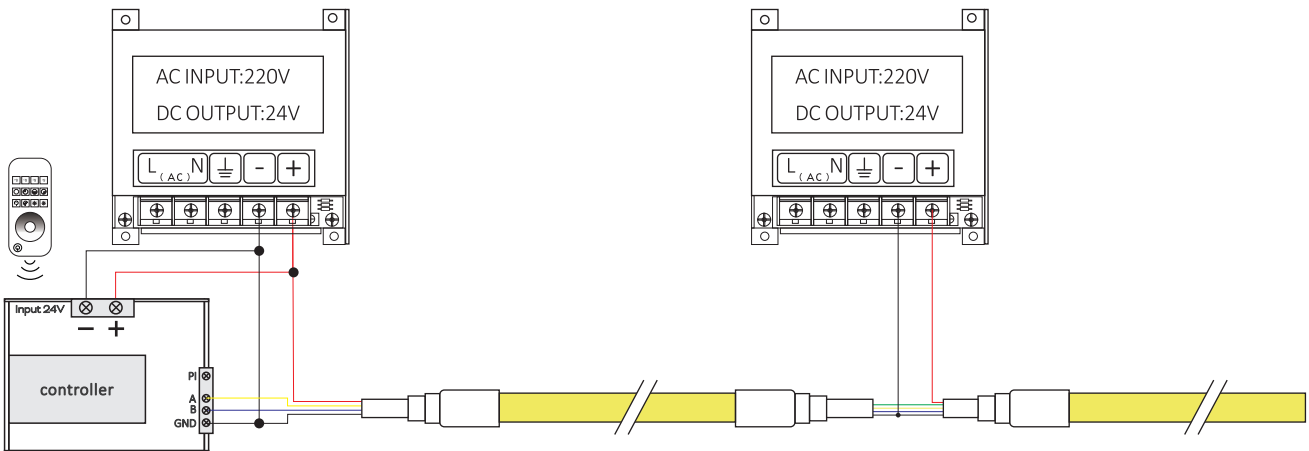

Package

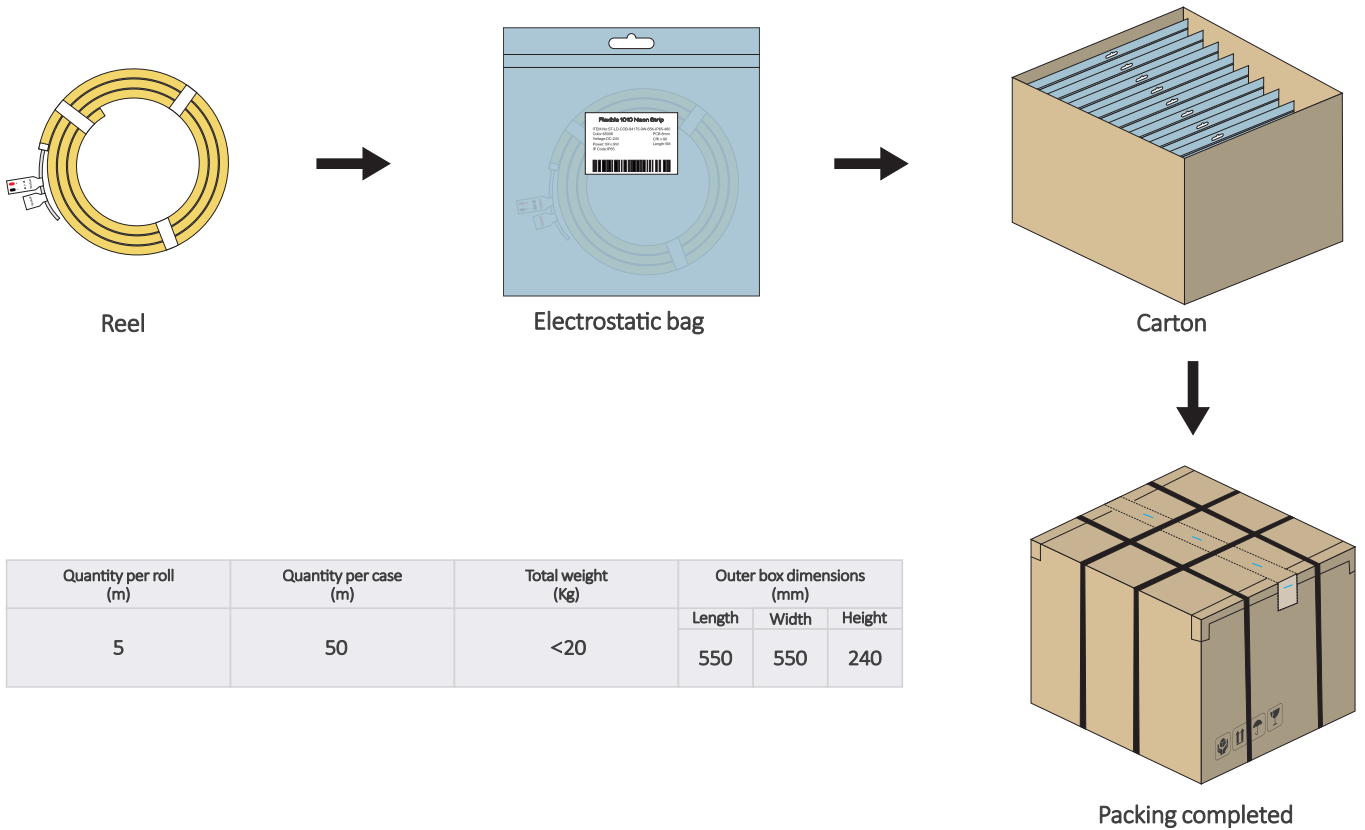

Quantity per roll (m)	Quantity per case (m)	Total weight (Kg)	Outer box dimensions (mm)		
			Length	Width	Height
5	50	<20	550	550	240

Note :The above-mentioned packaging quantity and weight are only for the packaging method shown in the figure. There will be differences in the number and weight of packaging for other packaging methods, and the actual product shall prevail.

Common product faults and their troubleshooting methods

Fault Phenomena	Possible Causes	Troubleshooting Methods
All lights off	1.Mains power failure	Power on
	2.Open circuit or short circuit at switching power supply output triggering auto-protection	Troubleshoot and restore power
	3.Reverse polarity at LED strip power input	Check wire connection status to ensure correct polarity
Partial lights off	1.Partial switching power supply failure	Inspect power supply system and resolve faults
	2.Wiring error in partial LED strip circuits	
	3.Reverse polarity in partial LED strips	Correct wiring
LED uneven brightness or insufficient brightness	1.Power supply overload	Replace with higher-power supply according to load
	2.Excessive line loss in switching power circuits or significant line loss discrepancies	Maintain LED strip operating voltage within $\pm 5\%$ of rated voltage 1.Shorten power cable length between power supply and LED strip or use larger gauge wires; 2.Ensure number of LED strips per circuit \leq max allowed cascading quantity and keep cascading quantities similar per circuit).
	3.Excessive serial connection of LED strips	Adjust LED strip quantity per power branch to meet max allowed cascading requirements per circuit
LED flickering	1.Poor contact at connection points	Identify and resolve poor contact points
	2.Switching power supply malfunction	Replace switching power supply

Notice

– If the external flexible cable of this product is damaged, the cable must be replaced by the manufacturer or similarly qualified personnel to prevent hazards.

-For specific installation arrangements and precautions, refer to the product user manual.

-Data in this specification is based on standard products, Actual delivered products may vary, subject to physical measurements

-All product diagrams in this specification are schematic diagrams, Actual delivered products may differ, subject to physical objects

-Technical modifications may be implemented without prior notice.

-Shenzhen Meishang Lighting Co., Ltd. reserves the final interpretation rights of this manual.



Specialized
LED Strip Manufacturer

Shenzhen
Relight Technology Co.,Ltd

6th Floor, Building A, Guancheng IndustrialPark,Gongming Town,
Guangming District, Shenzhen, China

Tel: 86 0755 3369 1713
Web: www.relight-tech.com
E-mail: Sales@relight-tech.com